

**Part One: Equations of a Circle**

1. I can find the center and radius of a circle given its equation. D1

a.  $(x + 2)^2 + (y - 3)^2 = 25$

b.  $(x - 1)^2 + y^2 = 40$

2. I can write an equation for a circle given key characteristics. D3-D4

a. Center: (-2, 5); Radius: 7

b. Center: (7, 0); Circumference:  $24\pi$

c. Center: (-2,7); Point on Circle: (6,-5)

d. Ends of a diameter: (2, -2) and (4,-6)

3. I can complete the square to write an equation for a circle in standard form and use it to find its center and radius. D2-D3

a.  $y^2 + x^2 = -12x + 2y + 27$

b.  $14x + 6y + 22 = -x^2 - y^2$

c.  $x^2 + y^2 - 6x + 11y + 3.25 = 0.$

## Part Two: Three Dimensional Solids

4. I can use multiple volume formulas together to find the volume of composite shapes. D5-D7

a. Find the volume of the pyramid to the right. Show your work.

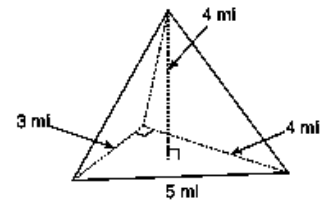

b. Suppose a cone was constructed around the pyramid in such a way that the base of the pyramid was inscribed in the base of the cone and the cone had a height of 4.5 mi. Find the volume of the cone. Show your work.

c. Ms. Pace had a special dog house built for her dog, Franklin. Find the volume (living area) of this house if the diameter of the base is 6 feet and the total height is 8 feet. The distance from the floor to the lowest part of the roof is 5.75 feet.



5. I can compare volumes of the same shape with different dimensions to determine which dimension has a greater effect. D6

A cylinder has a diameter of 10 cm and a height of 10 cm. Which would have a greater effect on the volume, doubling the diameter or doubling the height? Explain your reasoning.

6. I can use volume and surface area to solve contextual problems. D8

a. Find the total volume of the storage barn on the right. Round your answer to the nearest tenth. Show your work.

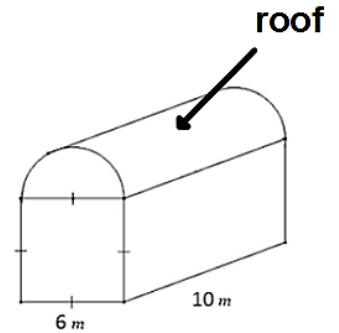

b. Suppose the owner wanted to paint the roof red and the rest of the building black. One gallon of exterior paint covers about 30 square meters. Each gallon cost \$16.03 with taxes included. Find the cost of the minimum amount of paint needed to put two coats on the roof and a single coat of paint on the building. Show your work.

(Hint: Surface Area of a Cylinder =  $2\pi rh + 2\pi r^2$ )

7. I can find 3D solids from rotating 2D figures. D9

a. What 3D object is formed by rotating this triangle around line  $m$ ? Describe any known characteristics of the 3D shape.

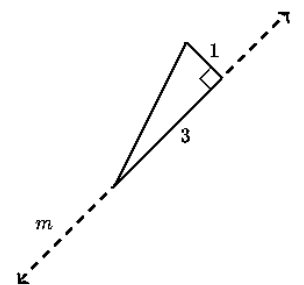

b. What 3D object is formed by rotating this rectangle around line  $m$ ? Describe any known characteristics of the 3D shape.

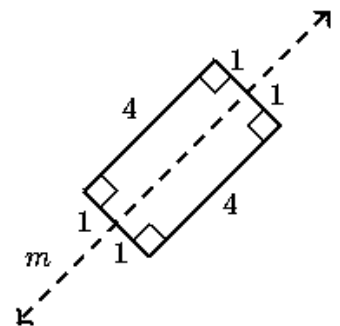

8. I can determine cross sections of 3D solids. D11

a. What 2D figure can we create by taking a horizontal cross-section of a cone? Name and sketch.

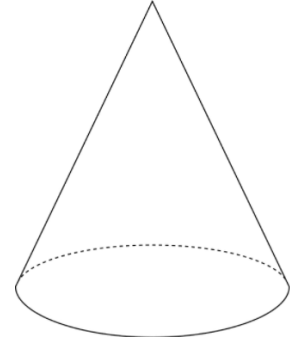

b. What 2D figure can we create by taking a vertical cross-section through the apex of a cone? Name and sketch.

c. What 2D figure can we create by taking a horizontal cross-section of this rectangular pyramid? Name and sketch.

d. What 2D figure can we create by taking a vertical cross-section of this rectangular pyramid that does not go through the apex? Name and sketch.

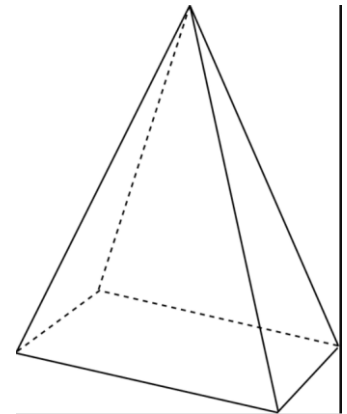

e. What is the greatest possible number of edges of a cross section created from a rectangular pyramid?

f. What 2D figure can we create by taking a horizontal cross-section of a cylinder? Name and sketch.

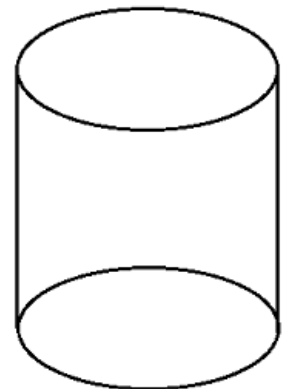

g. What 2D figure can we create by taking a vertical cross-section of a cylinder? Name and sketch.